

MILLING ACCESSORIES

CLAMP KITS - 52 piece



CODE	SLOT	STUD	WEIGHT	PRICE
C090	1/2"	3/8"UNC	9	
C091	5/8"	1/2"UNC	11	
C092	3/4"	5/8"UNC	15	
C094	5/8"	1/2"UNC	11	
C095	10mm	M8x1.25	7	
C0951	12mm	M10x1.25	9	
C096	14mm	M12x1.75	11	
C096A	16mm	M12x1.75	11	
C097	18mm	M16x2	15	
C099	22mm	M20x2.5	29	
C097A	18mm	M16x2	25	

• See page 51 for (C097A) CNC clamp kit

T-SLOT MINI CLAMP

- Low profile to allow the whole top surface to be machined
- Precision tool room accessory
- Drop forged steel
- Designed to pull down onto the table



Supplied individually

CODE	SLOT	G	F	H	PRICE
C0861	14mm	24mm	41mm	46mm	
C0871	16mm	27mm	50mm	55mm	
C0881	19mm	29mm	50mm	55mm	



FLANGED NUTS



CODE	SLOT	PRICE
N084	1/2"UNC	/pair
N086	M12	/pair
N088	M16	/pair

TEE NUTS

- Price is for a packet of 2

CODE	SLOT	STUD	A	B	C	PRICE
C084	5/8"	1/2"-13UNC	1" 11/32"	5/8"		
C085	10mm	M8	16	6	12.5	
C085A	12mm	M10	18	7	14	
C086	14mm	M12	22	8	16	
C087	16mm	M12	25	8	16	
C088	18mm	M16	28	11	20	



SLOTING ATTACHMENT

Suits most turret mills

- 125mm stroke
- 5-speed 30-140 strokes/min
- 3/4HP 415V Motor
- Comes complete with adjustable mounting bracket
- Weight: 180kg

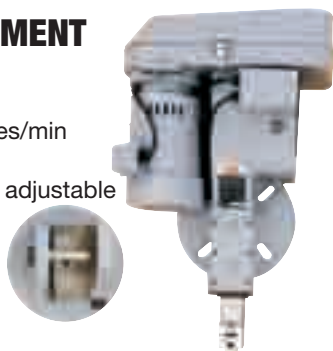

(M225)

HORIZONTAL ATTACHMENT

Suits most turret mills

Adjustable arbor support 140-170mm

CODE	TAPER	SPINDLE	PRICE
M214	R8	86mm	
M213	NT30	86mm	
M215	NT40	86mm	
M216	NT40	100mm	
M217	NT40	105mm	

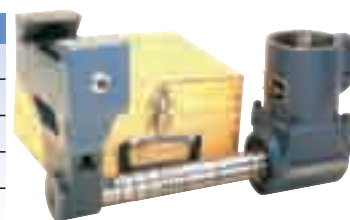

LOW VOLT HALOGEN LAMPS



(L283)

35 WATT



FLEXIBLE BENCH LAMP

(L283)

- Plastic shade & base for complete insulation
- 500mm long flexible arm & Magnetic base
- Built-in transformer 240V to 12V
- Weight 2kg



(L285)

55 WATT

CNC WARNING LIGHT

CNC WARNING LIGHT

(L281)

- 3 colour
- Pivot arm
- Non flashing
- 24V

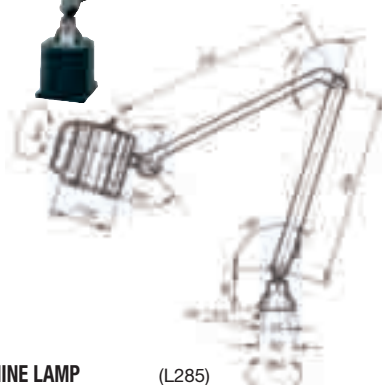

MACHINE LAMP

(L285)

- Diecast extruded aluminium finish
- 3 pivot arm, 830mm long
- Available without transformer
- Weight 3.5kg

FLUORESCENT MAGNIFYING LAMP



(L282)

22 WATT



FLUORESCENT LAMP

(L282)

- 5 x Magnifier lens
- 3 pivot arm, 830mm long
- 240V only
- Weight 3.5kg