

SWAGE & JENNY SJ-22

- Heavy duty cast iron
- 22G/0.8mm mild steel capacity
- 175mm throat
- Stroke on ram 20mm
- 50mm shaft to centre

INCLUDES:

5 sets of rolls, wiring, crimping, edge beading, single bead & elbow edging

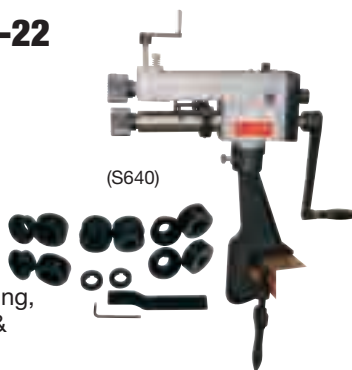

1/2" TO 2" WATER PIPE BENDER

2 SPEED PUMP

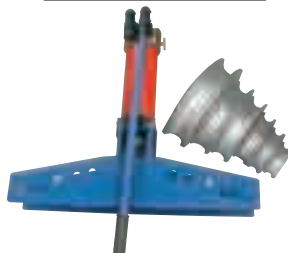

FEATURES:

- Complete with 6 pipe formers to suit (1/2", 3/4", 1", 1 1/4", 1 1/2", 2" water pipe)
- HYDRAULIC RAM - Requires less effort to bend pipe than bottle jack
- Designed to work horizontally
- Quick action flip over top frame for repetitive bends
- On cast wheels

(P064)

BAR BENDER BB-12

COLD BENDING: (steel)

- Flat 100x5mm
- Square 16x16mm
- Round 18mm dia.
- Angle 60x8mm

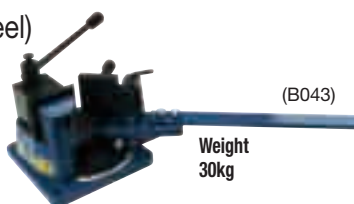

1/2" TO 2" WATER PIPE BENDER

12 TONNE JACK



FEATURES:

- Complete with 6 pipe formers to suit (1/2", 3/4", 1", 1 1/4", 1 1/2", 2" water pipe)
- Fitted with special long stroke 12 tonne hydraulic ram for one operation full bends and can be removed for use separately
- Designed to work on its side as well as vertically
- Spare formers and seal kits available

(P066)

SPARE RAM \$99 (P067)

TUBE BENDER

INCLUDES 8 FORMERS ROUND & SQUARE:

- 3/8" - 7/8" Round Cap.
- 3/4" - 1" Square Cap.

Includes plastic case



- Suitable for 1.2mm mild steel

HAND SHEARS

HAND SHEAR

HS6

(S186)

HS12

(S188)

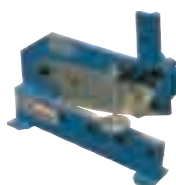

- FEATURES:
- Heavy duty steel fabricated blades
 - Spring return handles
 - High quality hardened blades
 - Spare blades available

HAND SHEAR

S/160

(S189)

S/200

(S191)

S/300

(S193)



HAND SHEAR

S/406

(S195)



HAND PUNCH

P/6

(P108)

P/10

(P110)



MODEL	HS6	HS12
CODE	S186	S188
SHEAR (mm)	4	6.5
FLAT (mm)	44 x 4.75	48 x 4.75
BLADE LENGTH	150	300
ROUND (mm)	9.5	12.7
WEIGHT (kg)	12	28

MODEL	S/160	S/200	S/300
CODE	S189	S191	S193
SHEAR mm	5	6	8
FLAT mm	70 x 6	70 x 7	70 x 6
BLADE/L	160	200	300
ROUND mm	11	12	13
WEIGHT (kg)	12.5	24.5	34

MODEL	S/406
CODE	S195
SHEAR mm (in)	8 (5/16")
FLAT mm (in)	100 x 10 (4" x 3/8")
ROUND mm (in)	16 (5/8")
ANGLE mm (in)	40 x 6 (1 1/2" x 1/4")
BLADE mm (in)	200 (8")
WEIGHT (kg)	46.6

MODEL	P/6	P/10
CODE	P108	P110
DIAMETER mm	10	16
THICK mm	6	10
THROAT mm	80	160
WEIGHT (kg)	12	76.5

N-16 ANGLE NOTCHER

- Ideal for a wide range of sheetmetal jobs
- Maximum 1.6mm capacity
- Cuts to 150mm x 150mm at 90°
- Stroke on ram 20mm
- Weight 95kg



STAND TO SUIT
\$195 (S247A)